



## Vertical Machining Center



**UM**  
Series

鈺基科技股份有限公司  
ACCUWAY MACHINERY CO., LTD.

42942台灣台中市神岡區豐工中路31號

No.31,Fenggong Central Rd., Shengang Dist., Taichung City 42942, Taiwan

TEL:886-4-2520-9588 FAX:886-4-2520-9716

E-mail: market@accuway.com.tw



# UM Series

## Structure

### + Super Rigid One-Piece Cast Bed

- Accuway's UM line of Vertical Machining Centers are made of Meehanite castings with an upgraded tensile strength and dampening capacity. They are heat treated to eliminate internal stresses and resist creep or fatigue under various operating conditions and thereby maintain accuracy even under prolonged cutting of even the toughest production part materials and tolerances.

### + Exceptionally Heavy Ribbed Structure

- The exceptionally heavy ribbing structure is geometrically symmetrical to balance the thermal and dynamic stresses ensuring the highest level of static and dynamic stability needed for constant precision cutting. This structure provides the optimal rigidity and torsional stiffness for high performance manufacturing.

### + Wide Guideway Span

- The extra wide linear guide span minimizes the bending deflection of the structure and provides a massive monolith base and support for heavy loads while maintaining a high level of accuracy. This also provides a stable cutting platform.

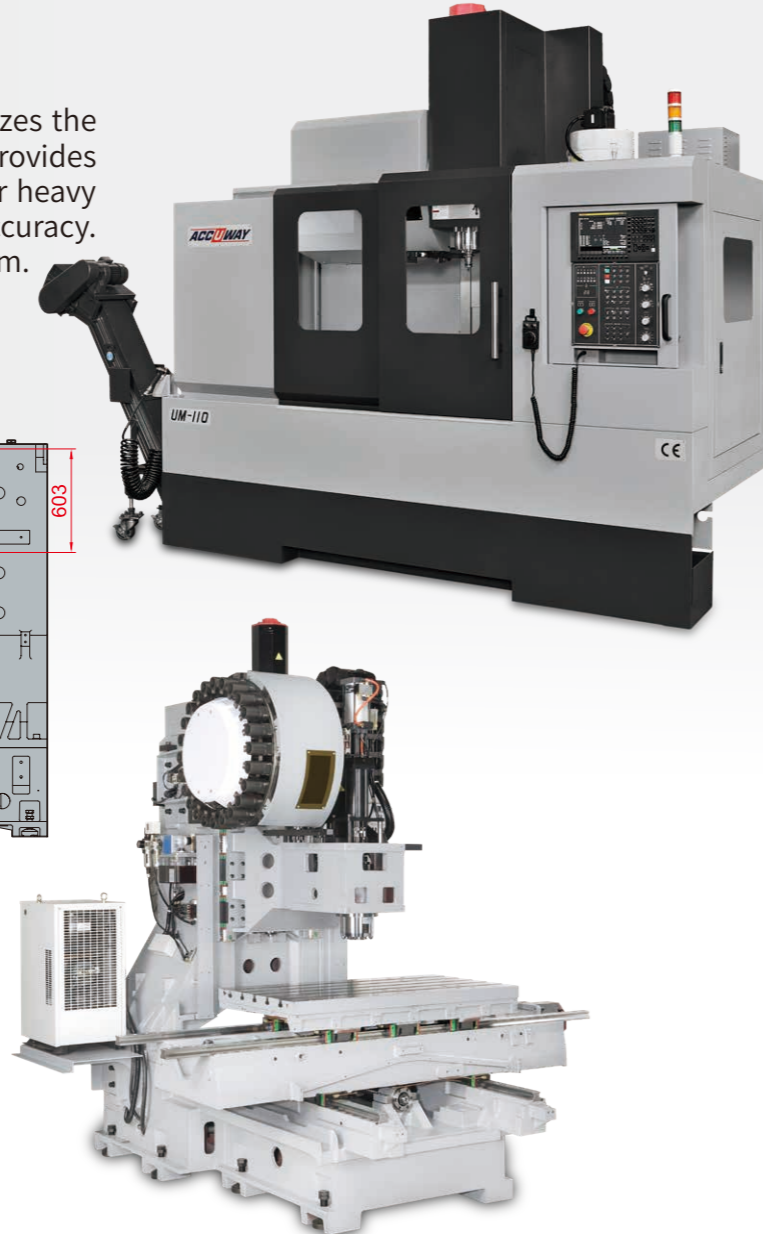
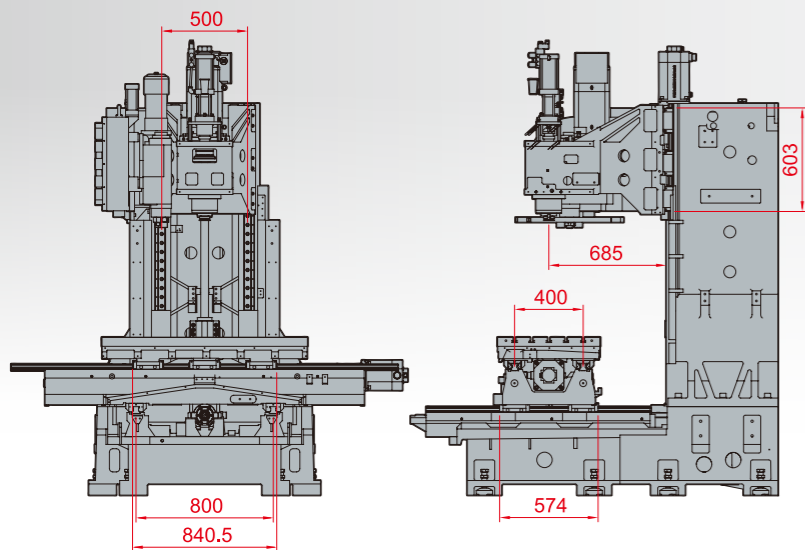

### ■ Column Cross Section

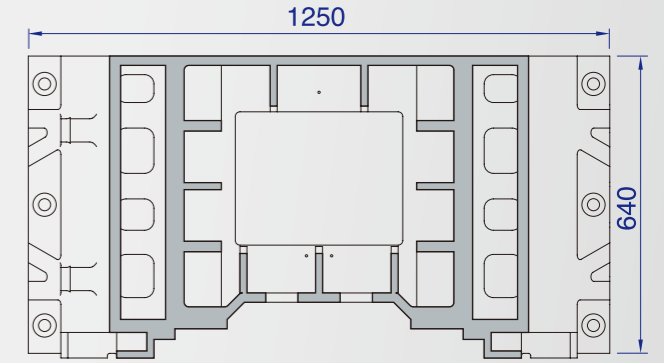

### ■ Saddle Cross Section

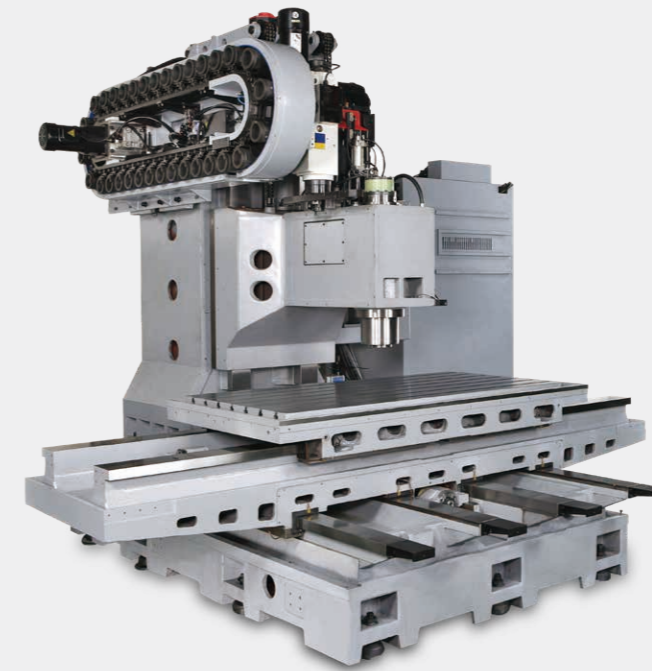
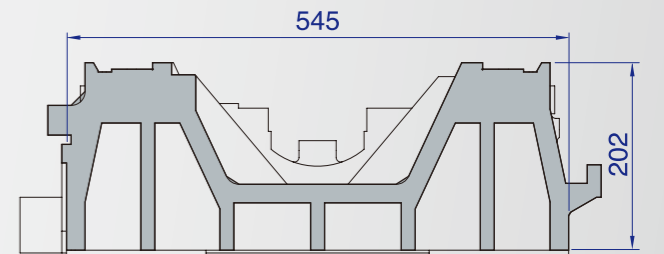

### + Advanced Design FEA Analysis

- With nearly 30 years of experience Accuway has amassed technical expertise and experienced engineers. They have developed the optimal machine structure design to provide the perfect balance of brute power stability and precision to build a compact machining center delivering high performance. With FEA analysis, years of client feedback and industry appraisal, Accuway has created the UM line with superb static and dynamic stability for constant precision cutting.

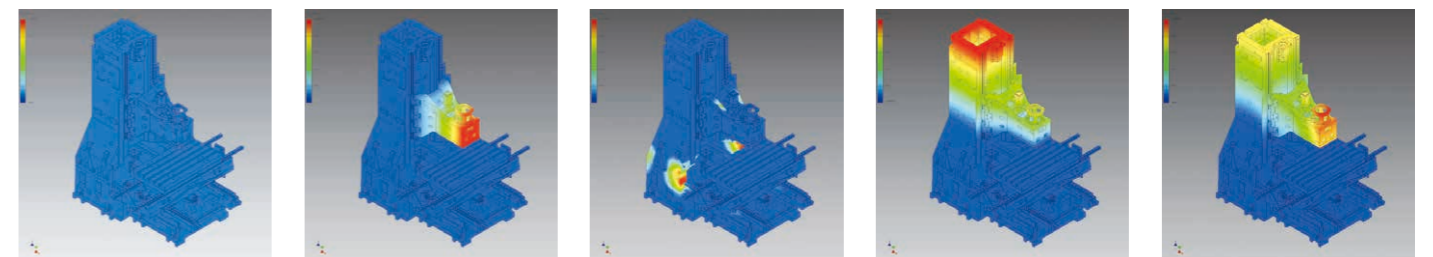
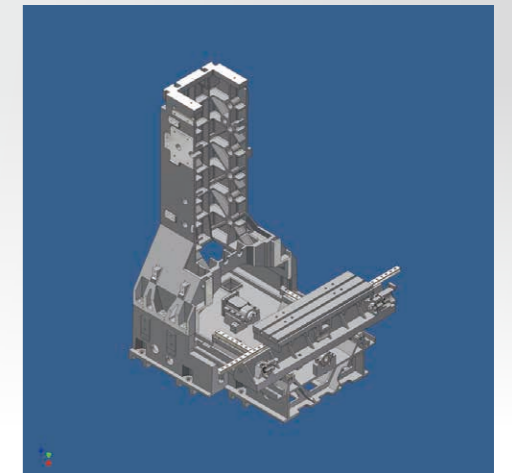

## + Precision Spindles

- Our precision spindles come with P4 class super precision bearings for strong axial resistance to counter cutting forces. They are permanently greased and lubricated for maximum lifetime and maintenance free requirements. All machines come standard with belt driven or direct drive couplings. Only high torque A.C. Spindle motors are used for supreme power, accuracy and reliability.



## + Spindle Coolant Chiller

- The large capacity spindle coolant chiller recirculates cooling oil through the spindle cartridge and machine headstock casting to maintain consistent positioning accuracy over a wide ambient temperature range.

## + Coolant Through Spindle

- For drilling and tapping small diameter deep precise holes we offer a coolant through spindle option. The coolant is dispersed directly at the machining point for eliminating chips that impact drill tip flutes and reduces broken tools.

## +Spindle Power Chart

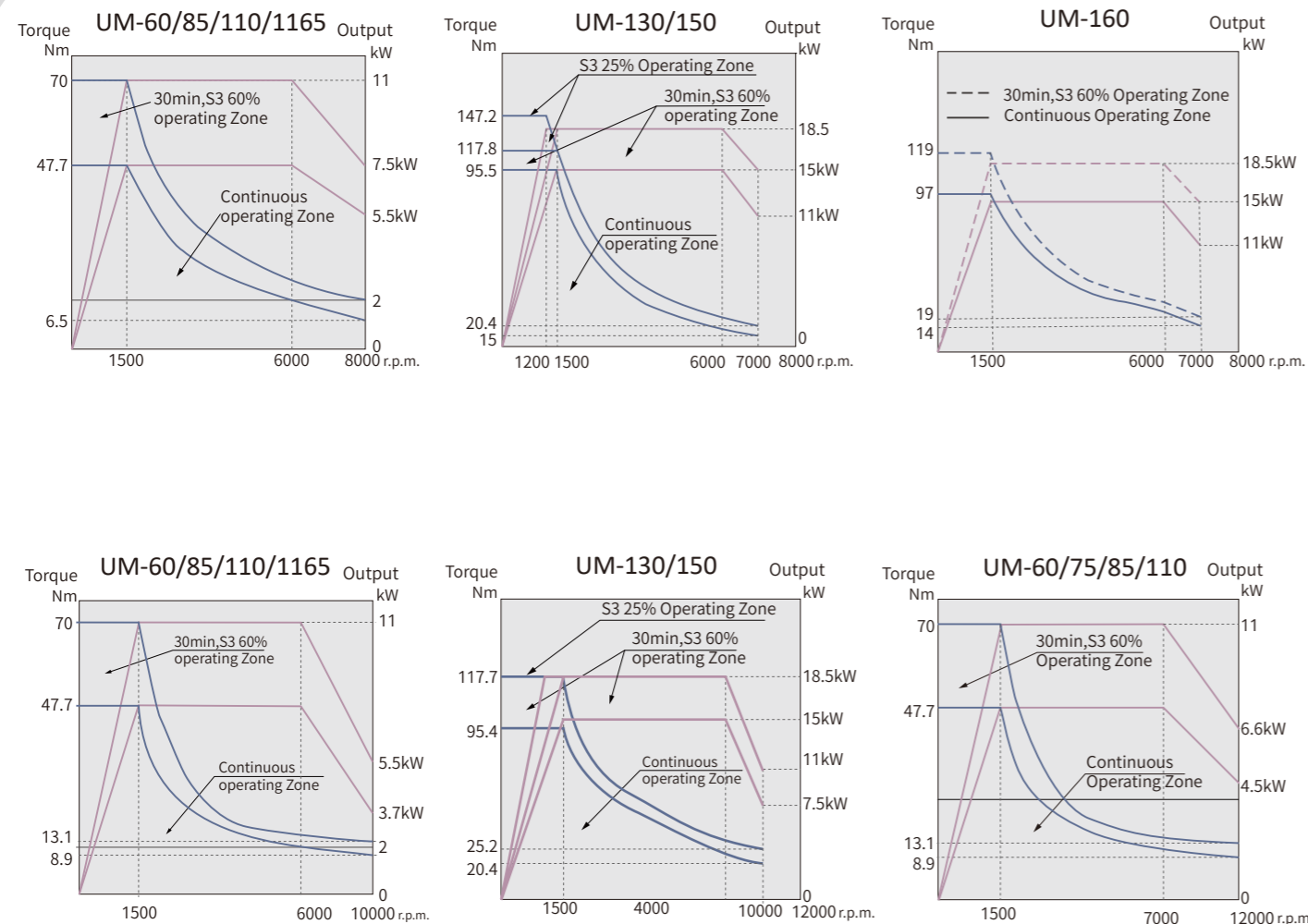

## + Ball Screws on All Axes

- Servo motors and ball screws are used on all axes and are direct coupled for virtually backlash free precise movement. With a low inertia and high efficiency output this combination offers excellent dynamic precision during contour machining.



## + Precision Guideways

- UM machines all have precision guideways coupled with ball screws for short machining times and longer tool life. Also the heavy-duty precision linear guideways with extra wide rails and a larger contact surface for superior frame rigidity.



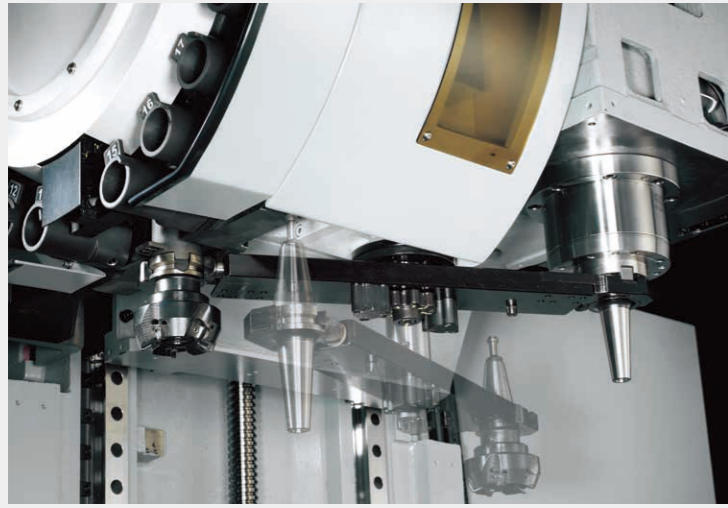

### + Automatic Tool Changer

- This Machine comes standard with a 24 tool magazine with highly efficient and fast tool changes to keep your pace of production high. An optional 32 tool magazine is also available.



### + Automatic Lubrication System filter

- Oil mist filters extract coolant and dust from the enclosed work area keeping it cleaner for high productivity and a safer work environment.



### + Oil Mist Collector

- Oil mist filters extract coolant and dust from the enclosed work area keeping it cleaner for high productivity and a safer work environment.

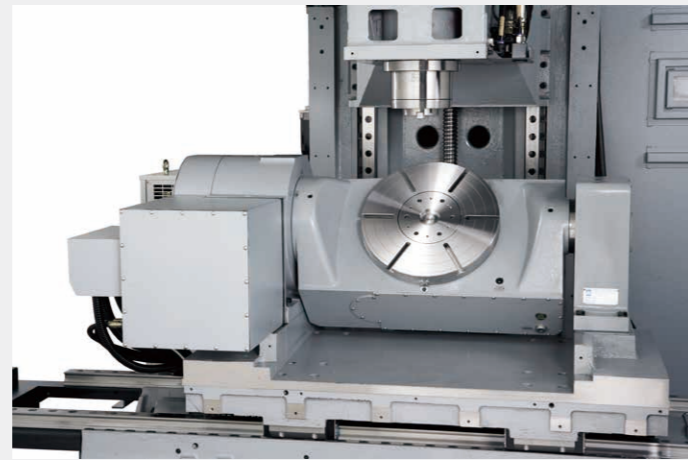
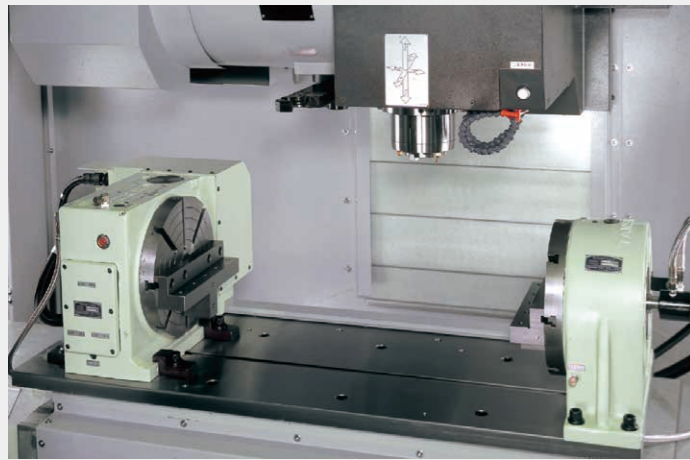

### + 2-axis Trunnion Rotary Table

- An optional 2-axis trunnion rotary table provides 5-axis machining capability for complex parts. This capability reduces tolerance deterioration due to multiple part transfer and jig change issues.

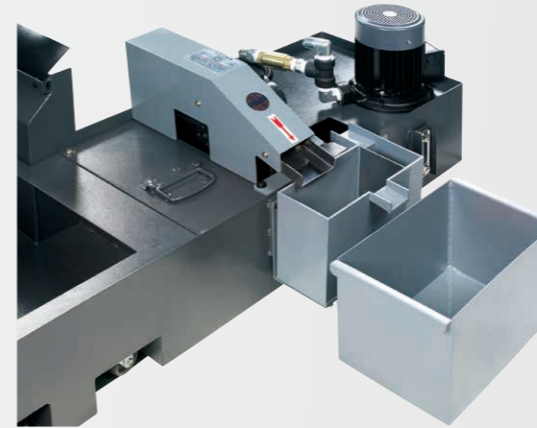

### + Oil Skimmer

- The oil skimmer removes oil slick from the coolant to maintain a cleaner work environment and it greatly reduces the operating cost and provides a greener environment.

### + Pull Stud & Tool Shank

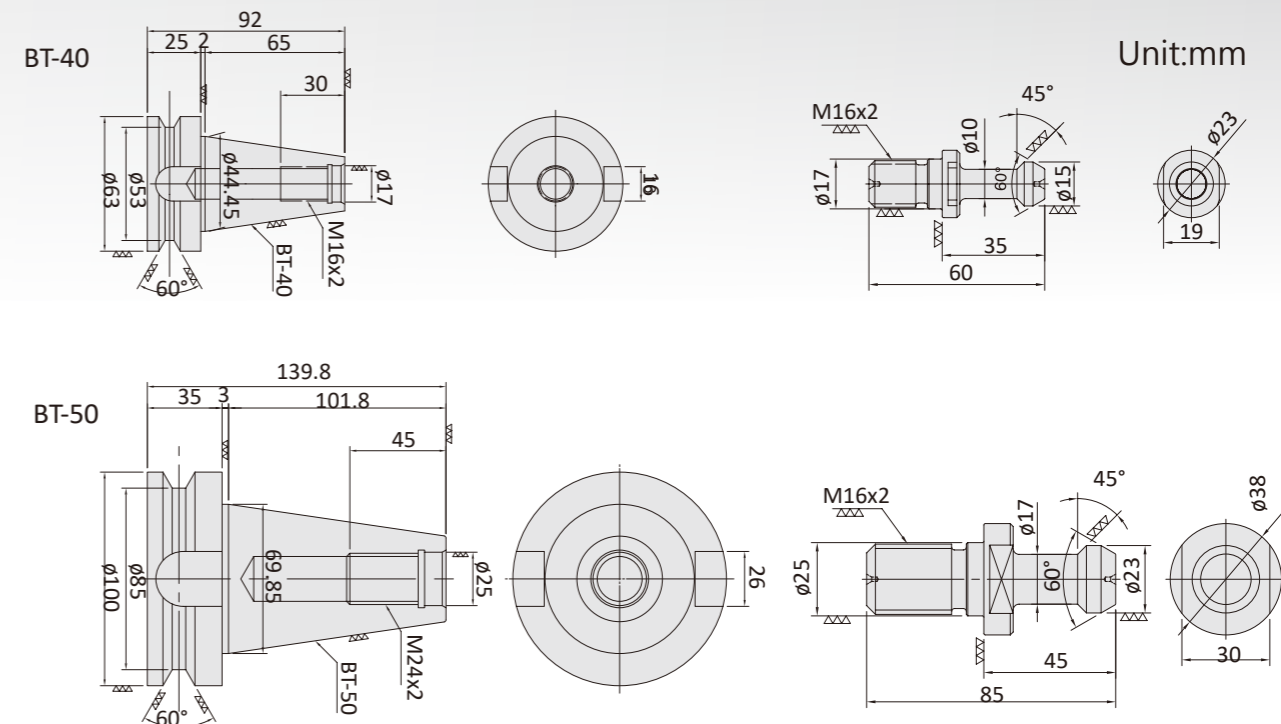

### + Control Panel

- A Fanuc control panel with touch screen is standard and optional Heidenhain or Mitsubishi are also available. Comes with a 90 degree swivel for quick programming and control of the machine.

### + Tool Setter

- This optional tool setting system can quickly check the tool length and diameter and gather compensation data for improving efficiency and reducing machine idle time.



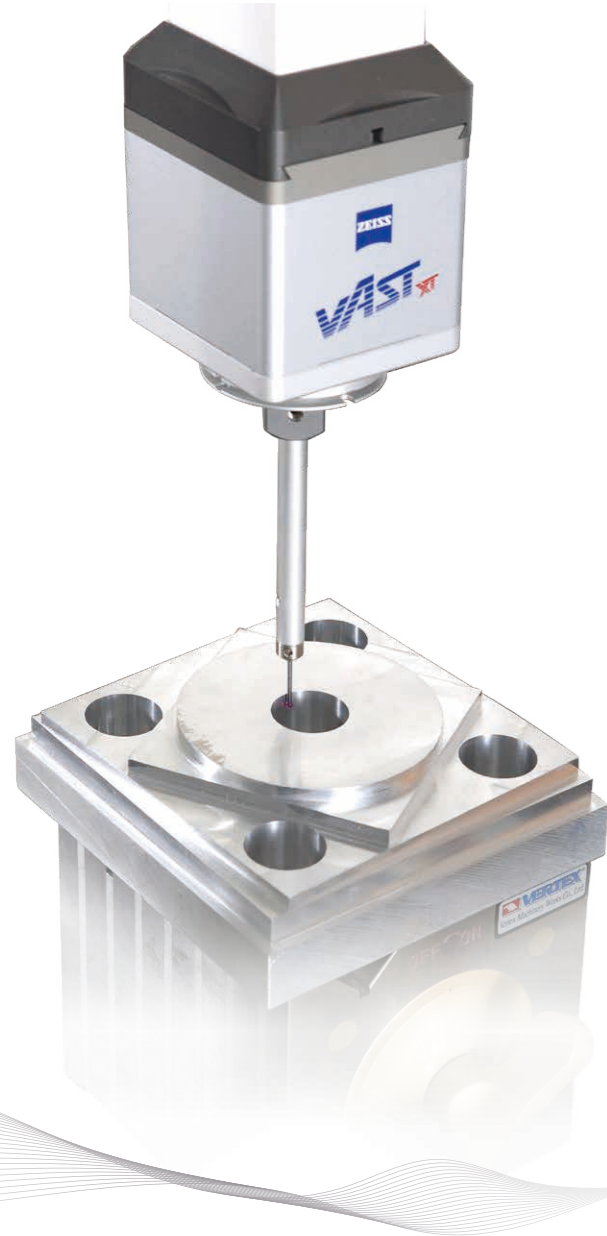

### + ISO Test Piece Cutting

Test pieces are cut for verification of machine capability and accuracy. The culmination of machine building, inspection, calibrations and compensation are checked against the CMM measurement results of the test pieces. This ensures your machine is built and will operate at a high level of accuracy for long-term use.

### + Machining Precision Results

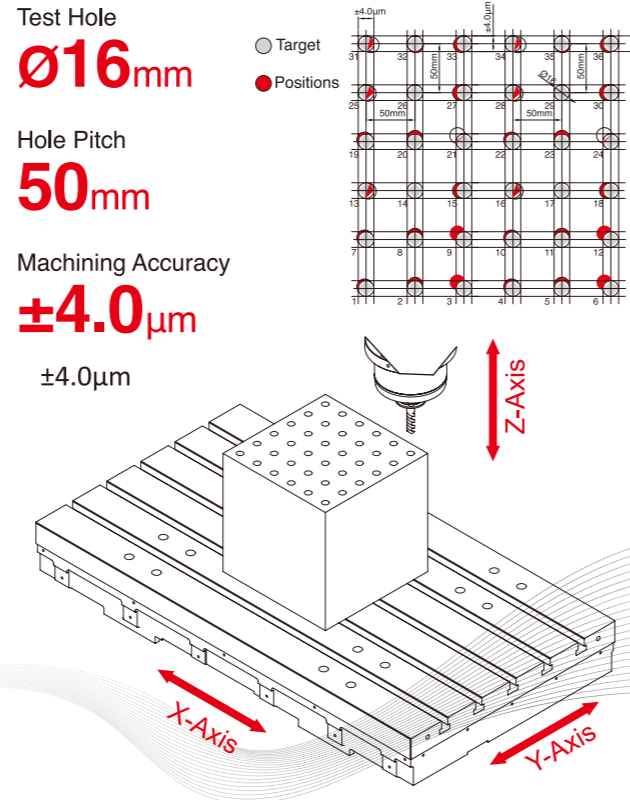

### +Ball Bar Test

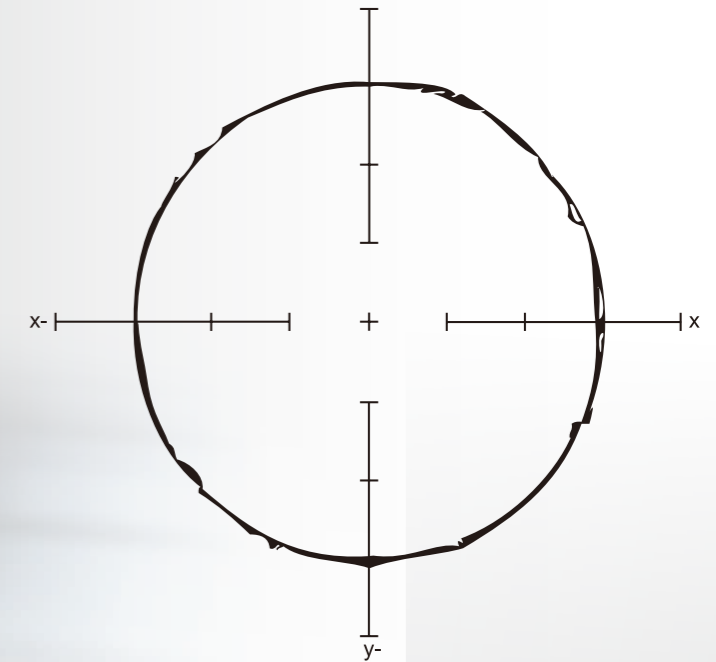
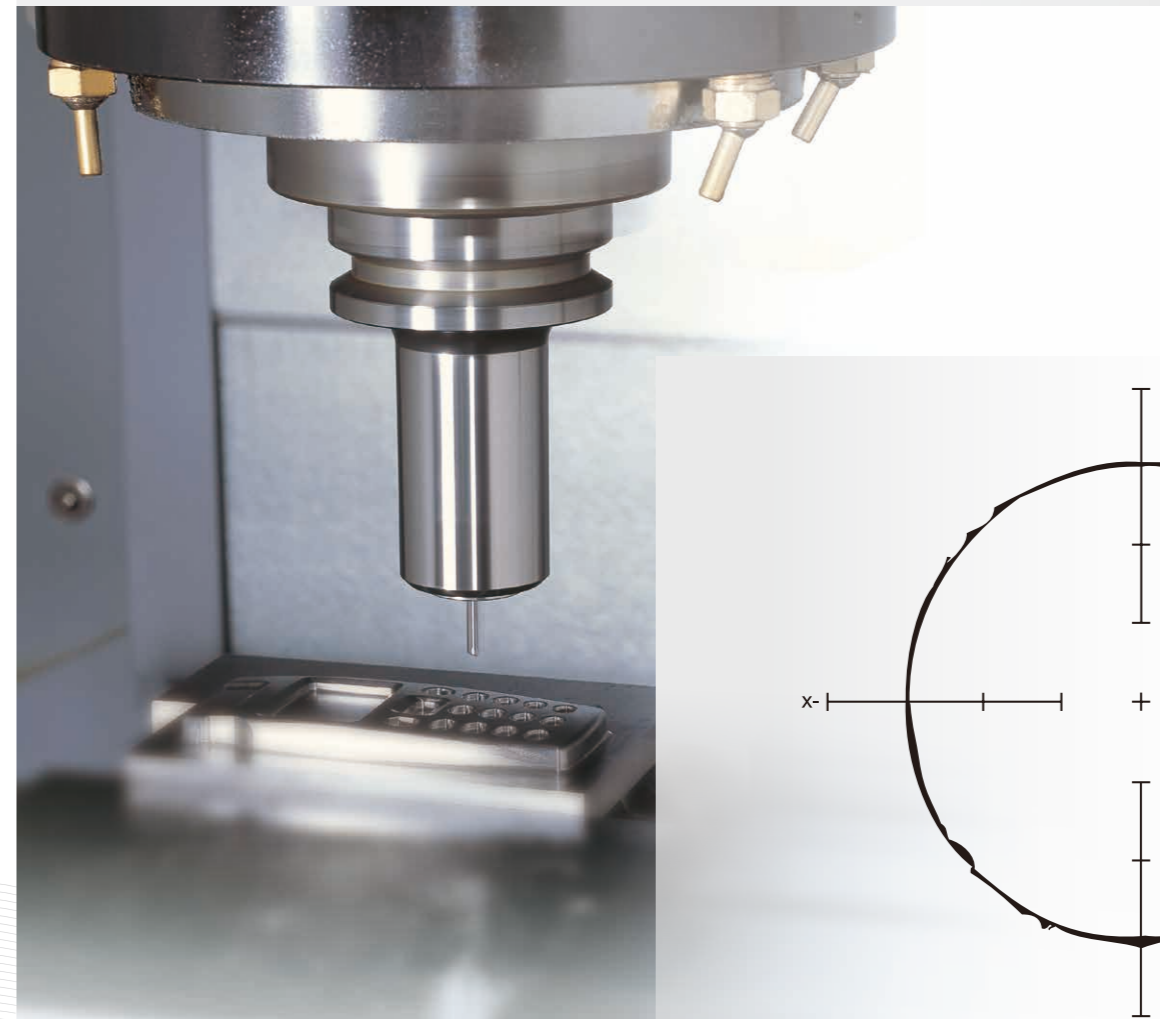

ISO230-4 results  
 Circular Deviation G, 1-cw : 3.5µm  
 Circular Deviation G, 2-ccw : 4.1µm  
 Circularity LSC : 4.5µm

/CW /CCW Scale 20.0µm



### + Ball Bar Test

■ The ball bar test is run to measure the error or difference in radius using software. This test can diagnose the error magnitude and shows the contouring performance and deviation. This guarantees your machine is calibrated and will provide high precision parts with high repeatability.

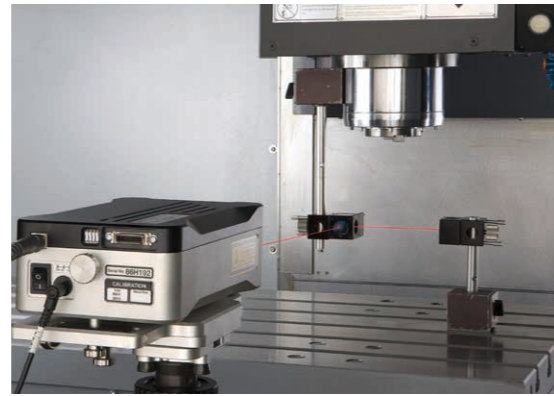

### + Laser Calibration

■ After careful machine assembly by trained professionals, Accuway uses advanced trained laser calibration equipment to precisely set your machine's accuracy. VDI 3441 measurement procedures are performed and this ensures these machines will provide the high accuracy and repeatability needed for high throughput manufacturing.

### + Accuracy Specification

ACCURACY Bi-directional [ISO 10791-4/ISO 230-2]

Machine Model	UNIT	ISO	UM-85H	UM-110H	UM-85	UM-110	UM-1165	ISO	UM-130	UM-150	UM-160
Positioning Full stroke -without Scales	µm	X	32	8	8	8	8	42	10	10	15
		Y	25	8	8	8	8	25	10	10	15
		Z	25	8	8	8	8	25	10	10	15
Positioning Full stroke -without Scales	µm	X	18	6	6	6	6	20	7	7	8
		Y	15	6	6	6	6	15	7	7	8
		Z	15	6	6	6	6	15	7	7	8
Circularity [φ300mm F1000]	µm	Y	N/A	6	6	6	6	N/A	6	6	10

## + System Diagram

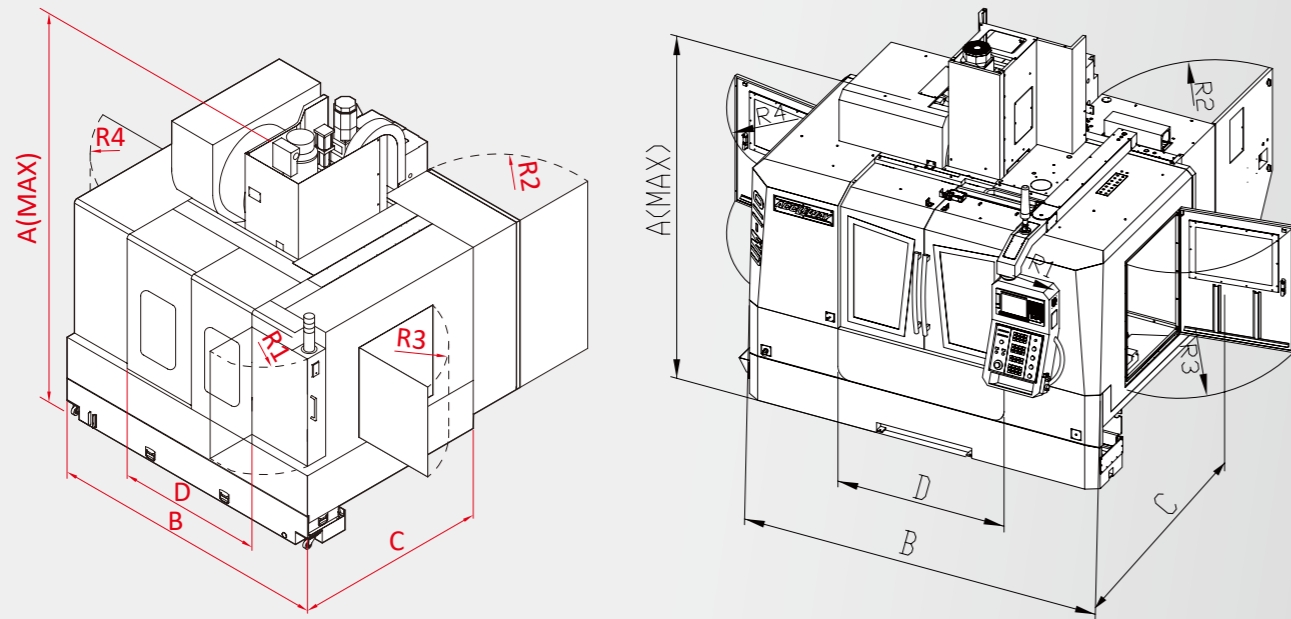

## + Machine Dimensions

Unit:mm

UM Series	60	85/85H	110/110H	120	130	150	160
A	2710	2980	2980	3010	2980	2980	3250
B	2000	2720	2950	3100	3300	3800	4400
C	2505	2230	2230	2230	2650	2800	3400
D	700	1160	1270	1270	1450	1600	1900
R1	440	580	566	566	540	540	475
R2	-	896	896	896	896	896	1040
R3	840	890	890	882	886	886	840
R4	840	890	890	882	886	886	840

## +Axial Travel Strokes

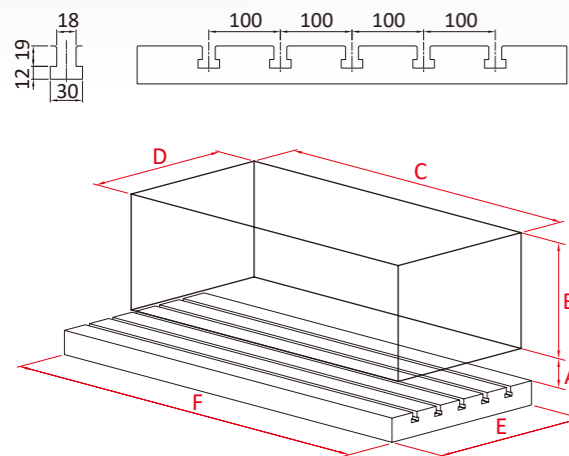

Unit:mm

	60	85/85H	110/110H	120	130	150	160
A	150	150	150	130	150	150	200
B	510	550	550	600	550	550	850
C	600	850	1100	1100	1300	1500	1600
D	510	550	550	650	650	750	850
E	560	600	600	650	650	770	880
F	750	1100	1200	1200	1500	1600	1700

## + Peripheral Equipment

ITEM / MODEL	UM-85H	UM-110H	UM-60	UM-85	UM-110 UM-120	UM-130	UM-150	UM-160	UM-110W
<b>Controller</b>									
FANUC 31i-B	○	○	○	○	○	○	○	○	○
FANUC 0i-M	●	●	●	●	●	●	●	●	●
AICC II	○	○	○	○	○	○	○	○	○
8.4" Colored LCD monitor	●	●	●	●	●	●	●	●	●
10.4" Colored LCD monitor	○	○	○	○	○	○	○	○	○
MPG Handwheel	●	●	●	●	●	●	●	●	●
Rigid tapping	●	●	●	●	●	●	●	●	●
Heat exchanger for electric cabinet	●	●	●	●	●	●	●	●	●
Mitsubishi/Heidenhain/Siemens controller	○	○	○	○	○	○	○	○	○
<b>Spindle</b>									
6000rpm	-	-	-	○	○	○	○	●	●
8000rpm	-	-	●	●	●	●	●	○	○
10000rpm	-	-	○	○	○	○	○	-	-
12000rpm	●	●	○	○	○	○	○	-	-
15000rpm	○	○	○	○	○	○	○	-	-
Spindle hole size BT40	●	●	●	●	●	●	●	○	○
Spindle hole size BT50	-	-	○	○	○	○	○	●	●
Spindle motor power15/18.5kW (Cont. / 30min)	○	○	-	○	○	●	●	●	●
Spindle oil cooling system	●	●	●	●	●	●	●	●	●
Coolant through spindle system	○	○	○	○	○	○	○	○	○
<b>Accessories</b>									
Lubrication system	●	●	●	●	●	●	●	●	●
4-bar coolant system	●	●	●	●	●	●	●	●	●
Cutter air blast	●	●	●	●	●	●	●	●	●
32 station tool magazine	○	○	○	○	○	○	○	○	○
Back side caterpillar type chip conveyor	●	●	●	●	●	●	●	●	●
Chain type chip conveyor + chip cart	○	○	○	○	○	○	○	○	○
Twin screw type chip conveyor	-	○	-	○	○	○	○	○	○
Spray gun	●	●	●	●	●	●	●	●	●
Three-color warning light	●	●	●	●	●	●	●	●	●
Linear scale (Heidenhain)	○	○	○	○	○	○	○	○	○
Contact tool setter [Renishaw/Metrol]	○	○	○	○	○	○	○	○	○
4th / 5th axis interface	○	○	○	○	○	○	○	○	○
Oil mist collector	○	○	○	○	○	○	○	○	○
Oil-coolant skimmer	○	○	○	○	○	○	○	○	○
Column reiser block 80mm	○	○	○	○	○	○	○	○	○
Gear box BT50	-	-	-	○	○	○	○	○	○
<b>4th axis rotary table</b>									
200mm 4th axis rotary table	○	○	○	○	○	○	○	○	○
250mm 4th axis rotary table	○	○	○	○	○	○	○	○	○
320mm 4th axis rotary table	○	○	-	○	○	○	○	○	○

● Standard Accessories ○ Optional Accessories - Not available

## + Specifications

ITEM / MODEL		UM-60	UM-85	UM-85H	UM-110	UM-110H	UM-120	UM-120B	UM-130	UM-150	UM-160S	
Controller		FANUC 0i-M	FANUC 0i-M	FANUC 0i-M	FANUC 0i-M	FANUC 0i-M	FANUC 0i-M	FANUC 0i-M	FANUC 0i-M	FANUC 0i-M	FANUC 0i-M	
<b>SPINDLE</b>												
Spindle speed	rpm	10000(12000)	10000 (12000)	12000(15000)	10000(12000)	12000(15000)	10000(12000)	10000(12000)	10000(12000)	10000(12000)	10000(12000)	
Spindle nose taper	-	BT40	BT40	BT40	BT40	BT40	BT40	BT40	BT40	BT40	BT40	
Bearing inner diameter	mm	70	70	70	70	70	70	70	70	70	70	
Drive system	-	Belt (Direct)	Belt (Direct)	Direct	Belt (Direct)	Direct	Belt (Direct)	Belt (Direct)	Belt (Direct)	Belt (Direct)	Belt (Direct)	
<b>TRAVELS</b>												
X-axis travel	mm	600	850	850	1100	1100	1200	1200	1300	1500	1600	
Y-axis travel	mm	520	550	550	550	550	650	650	650	750	850	
Z-axis travel	mm	540	550	550	550	550	600	600	550	550	850	
Spindle nose to table	mm	150~690	150~700	150~700	150~700	150~700	125~725	150~750	150~700	150~700	150~1000	
<b>TABLE</b>												
Table dimension	mm	750 x 560	1100 x 600	1100 x 600	1200 x 600	1200 x 600	1200 x 650	1300 x 650	1500 x 650	1600 x 770	1700 x 950	
T-slot(No. of T-slot x width x pitch)	mm	5 x 18 x 100	5 x 18 x 100	5 x 18 x 100	5 x 18 x 100	5 x 18 x 100	5 x 18 x 100	5 x 18 x 120	5 x 18 x 100	7 x 18 x 100	9 x 18 x 100	
Max. weight on table	kg	750	1000	1000	1200	1200	1300	1200	1500	1500	2000	
<b>FEED RATES</b>												
X-axis Rapid Traverse Rate	m / min	36	30	42	30	42	30	24	30	30	30	
Y-axis Rapid Traverse Rate	m / min	36	30	42	30	42	30	24	30	30	30	
Z-axis Rapid Traverse Rate	m / min	30	30	36	30	36	30	24	30	30	30	
Cutting feed rate	m / min	12	12	12	12	12	12	12	12	12	12	
Ball screw diameter(X/Y/Z)	mm	40/40/40	45/45/45	45/45/45	45/45/45	45/45/45	45/45/45	45/45/45	45/45/45	45/45/45	50/50/50	
Guideway type		Ball	Ball	Ball	Ball	Ball	Ball	Box	Ball	Ball	Ball	
<b>AUTOMATIC TOOL CHANGE SYSTEM</b>												
Tool magazine capacity	pcs	24	24(30/32)	24(30/32)	24(30/32)	24(30/32)	24(30/32)	24(30/32)	24(30/32)	24(30/32)	24(30/32)	
Max.tool weight	kg	7	7	7	7	7	7	7	7	7	7	
Max.tool diameter	mm	75	75	75	75	75	75	75	75	75	75	
Max.tool diameter without adjacent tools	mm	150	150	150	150	150	150	150	150	150	150	
Method of tool exchange	-	Arm type	Arm type	Arm type	Arm type	Arm type	Arm type	Arm type	Arm type	Arm type	Arm type	
Max. tool length	mm	300	300	300	300	300	300	300	300	300	300	
<b>MOTOR</b>												
AI contour control		AICC I (AICC II)	AICC I (AICC II)	AICC I (AICC II)	AICC I (AICC II)	AICC I (AICC II)	AICC I (AICC II)	AICC I (AICC II)	AICC I (AICC II)	AICC I (AICC II)	AICC I (AICC II)	
Spindle motor power(Cont. / 30min)	kW	7.5 / 11	7.5/11(15/18.5)	7.5/11 (15/18.5)	7.5/11 (15/18.5)	7.5/11(15/18.5)	7.5/11(15/18.5)	7.5/11(15/18.5)	15/18.5	15/18.5	15/18.5	
X/Y/Z feed motor	kW	3/3/4	3/3/4	3/3/4	3/3/4	3/3/4	3/3/4	3/3/4	4/4/7	4/4/7	4/4/7	
Coolant pump otor (50Hz/60Hz)	kW	0.53+0.85/0.75+1.27					0.75+1.27(1.01+1.73)			0.53+0.85/0.75+1.27		
<b>OTHERS</b>												
Air supply	kg/cm <sup>2</sup>	5.5	5.5	5.5	5.5	5.5	5.5	5.5	5.5	5.5	5.5	
Machine dimension L x W x H	m	2 x 2.6 x 2.8	2.8 x 2.3 x 3.0	2.8 x 2.3 x 3.0	3.1 x 2.3 x 3.0	3.1 x 2.3 x 3.0	3.1 x 2.3 x 3.1	3.1 x 2.3 x 2.8	3.3 x 2.7 x 3	3.8 x 2.8 x 3.0	4.4 x 3.4 x 3.3	
Net weight	kg	5000	7000	7000	7500	7500	7500	7500	8000	9500	14000	

## + Specifications

ITEM / MODEL		UM-110W	UM-120W	UM-120WB	UM-130W	UM-150W	UM-160	UM-210
Controller		FANUC 0i-M	FANUC 0i-M	FANUC 0i-M	FANUC 0i-M	FANUC 0i-M	FANUC 0i-M	FANUC 0i-M
<b>SPINDLE</b>								
Spindle speed	rpm	6000	6000	6000	6000	6000	6000	6000
Spindle nose taper	-	BT50	BT50	BT50	BT50	BT50	BT50	BT50
Bearing inner diameter	mm	90	90	90	90	90	90	90
Drive system	-	Belt	Belt	Belt	Belt	Belt	2-step gearbox	2-step gearbox
<b>TRAVELS</b>								
X-axis travel	mm	1100	1200	1200	1300	1500	1600	2100
Y-axis travel	mm	550	650	650	650	750	850	850
Z-axis travel	mm	550	600	600	550	550	850	850
Spindle nose to table	mm	150~705	130~730	150~750	155~705	150~700	150~1000	150~1000
<b>TABLE</b>								
Table dimension	mm	1200 x 600	1200 x 650	1300 x 650	1500 x 650	1600 x 770	1700 x 880	2200 x 980
T-slot(No. of T-slot x width x pitch)	mm	5 x 18 x 100	5 x 18 x 100	5 x 18 x 120	5 x 18 x 100	7 x 18 x 100	7 x 18 x 120	8 x 18 x 120
Max. weight on table	kg	1200	1200	1200	1500	1500	2000	2500
<b>FEED RATES</b>								
X-axis Rapid Traverse Rate	m / min	30	30	24	30	30	15	15
Y-axis Rapid Traverse Rate	m / min	30	30	24	30	30	15	15
Z-axis Rapid Traverse Rate	m / min	30	30	24	30	30	15	15
Cutting feed rate	m / min	12	12	12	12	12	12	12
Ball screw diameter(X/Y/Z)	mm	45/45/45	45/45/45	45/45/45	45/45/45	45/45/45	50/50/50	50/50/50
Guideway type		Roller	Roller	Box	Roller	Roller	Box	Box
<b>AUTOMATIC TOOL CHANGE SYSTEM</b>								
Tool magazine capacity	pcs	24(32)	24(32)	24(32)	24(32)	24(32)	24(32)	24(32)
Max.tool weight	kg	15	15	15	15	15	15	15
Max.tool diameter	mm	105	105	105	105	105	105	105
Max.tool diameter without adjacent tools	mm	210	210	210	210	210	210	210
Method of tool exchange	-	Arm type	Arm type	Arm type	Arm type	Arm type	Arm type	Arm type
Max. tool length	mm	300	300	300	300	300	300	300
<b>MOTOR</b>								
AI contour control		AICC I	AICC I	AICC I	AICC I	AICC I	AICC I	AICC I
Spindle motor power(Cont. / 30min)	kW	15/18.5	15/18.5	15/18.5	15/18.5	15/18.5	15/18.5	22/26
X/Y/Z feed motor	kW	3/3/7	3/3/7	3/3/7	4/4/7	4/4/7	4/4/7	4/4/7
Coolant pump otor (50Hz/60Hz)	kW	0.53+0.85/0.75+1.27	0.53+0.85/0.75+1.27	0.53+0.85/0.75+1.27	0.53+0.85/0.75+1.27	0.53+0.85/0.75+1.27	0.53+0.85/0.75+1.27	0.53+0.85/0.75+1.27
<b>OTHERS</b>								
Air supply	kg/cm <sup>2</sup>	5.5	5.5	5.5	5.5	5.5	5.5	5.5
Machine dimension L x W x H	m	3.0 x 2.2 x 3.0	3.3 x 2.7 x 3.0	3.3 x 2.7 x 3.0	3.3 x 2.7 x 3.0	3.7 x 2.9 x 3.0	4.4 x 3.4 x 3.3	5.4 x 3.9 x 3.0
Net weight	kg	7500	8000	8000	9000	10000	15000	17000